

# Sunset Comò

Studiopepe  
2026



Comò con sei cassetti a estrazione totale. Struttura in legno curvato disponibile nelle seguenti finiture: frassino tinto nero a poro aperto oppure legno laccato opaco nei colori "Bianco Camargue", "Beige Matera", "Sabbia del Nilo", "Rosa Jaipur", "Rosso Persia", "Bordeaux Etruria", "Verde Provenza", "Blu Pacifico", "Grigio Londra", "Nero Giza".

Top in legno laccato opaco nei colori del campionario.

Disponibile anche rivestito in pelle fard nei colori del campionario oppure in marmo Arabescato Orobico Rosso satinato, Dover White satinato, Nero Marquinia levigato opaco e Travertino Romano spazzolato naturale (non resinato).

Frontali cassetti disponibili in legno laccato opaco nei colori del campionario oppure rivestiti in pelle fard nei colori del campionario.

Dettagli in ottone lucido.

**Cm (L x P x H)**  
140 x 54 x 74

**Inches (L x P x H)**  
55¼ x 21½ x 29¼

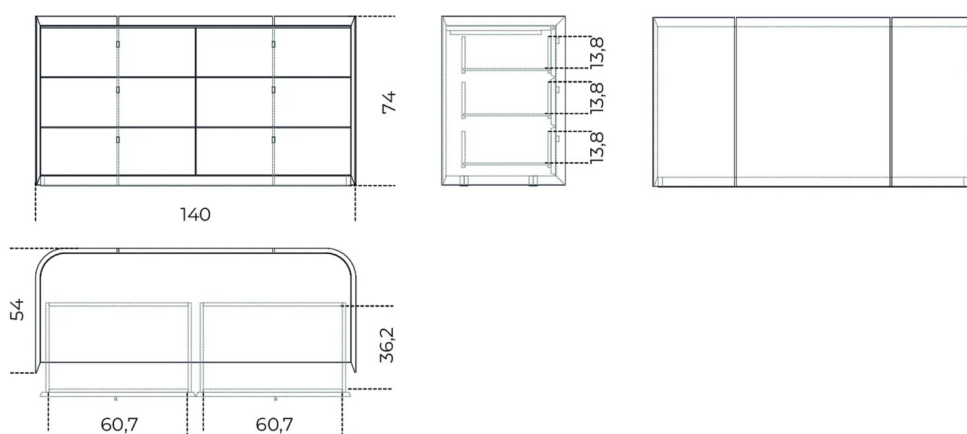

# Finiture

## Legno



"Beige Matera" laccato opaco



"Bianco Camargue" laccato opaco



"Blu Pacifico" laccato opaco

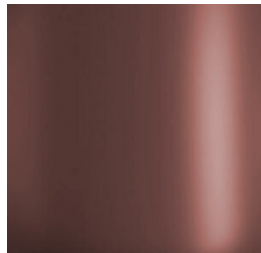

"Bordeaux Etruria" laccato opaco



"Grigio Londra" laccato opaco

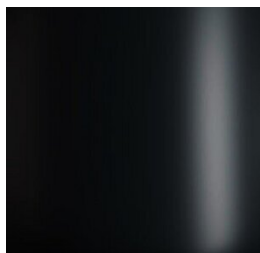

"Nero Giza" laccato opaco

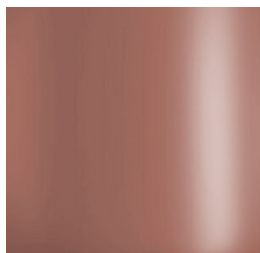

"Rosa Jaipur" laccato opaco

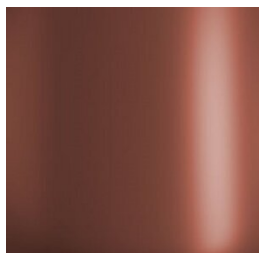

"Rosso Persia" laccato opaco



"Sabbia del Nilo" laccato opaco



Tinto nero poro aperto



"Verde Provenza" laccato opaco

## Metallo

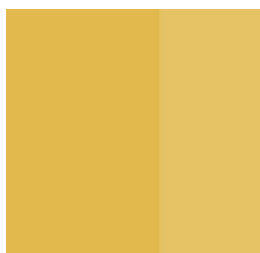

Ottone lucido

## Marmo



Dover white



Nero Marquina



Orobico Arabescato  
Rosso



Travertino romano

## Pelle Cat.L1



Fard amaranth 2337



Fard amber 2343

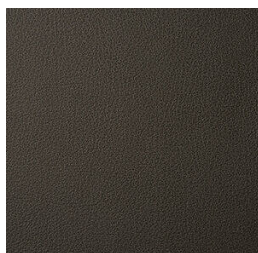

Fard anthracite 2379

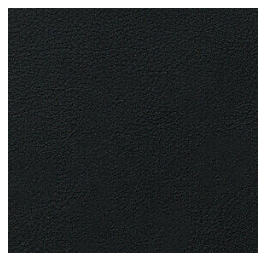

Fard black 2398

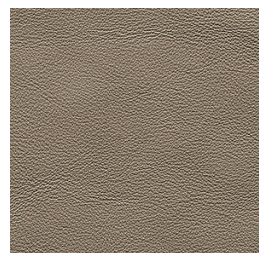

Fard clay 2303



Fard deer 2346



Fard ecru 2304

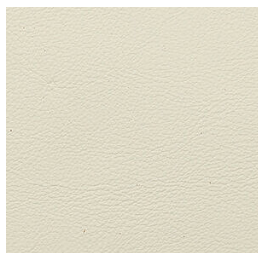

Fard ivory 2310



Fard loden green 2357



Fard milk 2300



Fard nude 2334



Fard otter 2348



Fard silt 2324

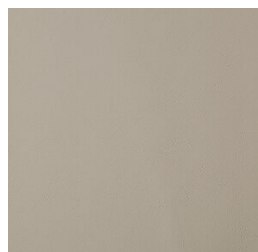

Fard silver 2302

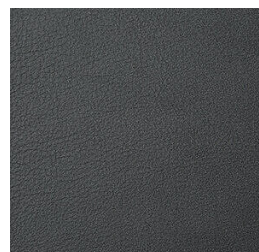

Fard slate 2386



Fard tan 2305